

# AeroSpace Research

## 68mm StarChaser 2 Rocket

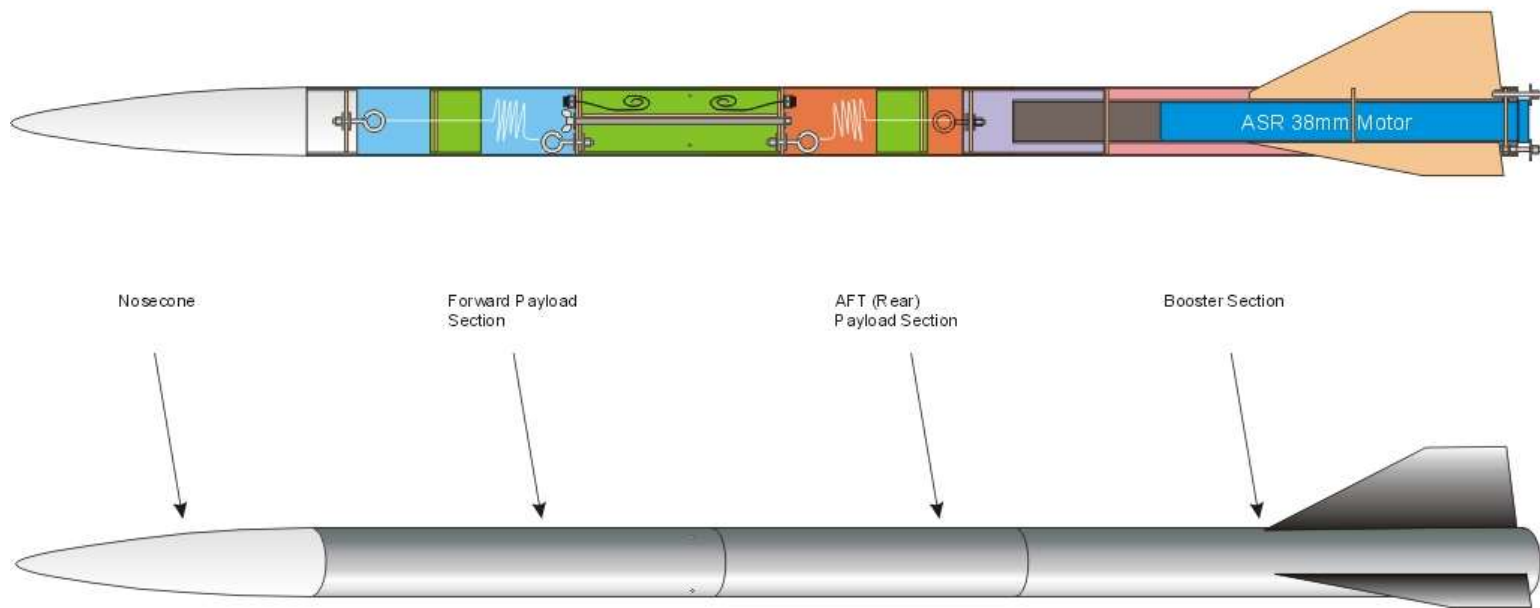

## Contents

[What you will need](#)

[Parts list](#)

[Preparing the Parts](#)

[The Motor Mount Tube Assembly](#)

[The Booster Assembly](#)

[Installing the Fins](#)

[The Electronics Bay](#)

[Final assembly](#)

[Finishing](#)

[Preparing the Rocket for flight](#)

[Appendix A - Fin Terminology](#)

[Appendix B - Recovery](#)

## ***What you will need***

Before you begin, make sure you have the following:

1. Sanding paper. At least 80, 100 and 220 grit. For wet sanding 600 or 1200 grit is best.
2. Pencil.
3. Masking tape. 10mm and 40mm. (close to these sizes are ok)
4. Ruler, steel is best. For marking and making straight cuts.
5. Small aluminium angle around 1m long. To make straight lines on the round tubes.
6. Stanley knife or similar.
7. Razor saw or similar.
8. Assorted drill bits.
9. Electric drill.
10. Epoxy glue. We recommend medium to long cure epoxy, which is stronger than 5-minute epoxy. To make it easier for you AeroSpace Research sells a kit that includes 1 litre of Epoxy and fillers for building your Rocket. Enquire about this where you bought this kit.
11. Fillers. Something like Cotton Flocks and Cabosil (fumed silica) can be used to thicken the epoxy for making fillets and to reduce the weight of the epoxy. Other fillers include Micro balloons, which allow the epoxy to be sanded easily.
12. CA (Cyanoacrylate) also known as Superglue. The thinnest you can get.
13. Wood glue. Also known as white glue.
14. Sanding Sealer for sealing tubes and wooden parts. Epoxy works well for this as well.
15. Plastic gloves. Makes messy work less so. You **HAVE** to use gloves when working with epoxy.
16. Paint Primer.
17. Paint. As many colours as you intend to use on your rocket. Aerolak and Spraymate are well-known brands of 'rattle' cans and work well.

## ***Parts list***

Before anything else, check that all parts are present. Here is a list of all parts you should have in your kit:

- Nosecone (1)
- Fins (3)
- Body tubes (68mm Cardboard Tubes), for Booster (500mm), Aft Payload (350mm) and Forward Payload (400mm) sections. (1 each)
- Coupler Tube (65mm Cardboard Tube), 200mm for Electronics bay (1)
- Coupler Tube (65mm Cardboard Tube), 140mm for Booster Coupler (1)
- Coupler Tubes (65mm Cardboard Tube), 40mm for Piston (2)
- Motor Mount tube (43mm Cardboard Tube), 500mm long (1)
- Centring Rings (CR) (3)
- Bulkheads (2 large)
- Bulkheads (6 small)
- 6mm Eyebolts (4).
- 6mm Bolt (230mm long) (1)
- 6mm Lock-Nuts (5)
- 6mm Nuts (6)
- 6mm Washers (11)
- Launch Lugs (2)
- Main Parachute (1)
- Drogue Parachute (1)
- Shock Cords (2)
- Quick-links (4)

If any of the above parts are missing or damaged, please contact us immediately so we can rectify the mistake. Johann 081 327 4934

## ***Preparing the Parts***

### Body Tubes

All tubes should be sanded smooth and CA (superglue) applied around the edges to make the edges stronger and resistant to fraying. The tube ends should be sanded again after the superglue has dried.

At this point you should decide whether you want to epoxy coat the tubes, apply a sanding sealer or just to leave the tubes as they are. We recommend epoxy coating the tubes for strength and durability, although it is not required. For more information about epoxy coating, visit [www.rocketry.co.za](http://www.rocketry.co.za) (click on SAASA) or give us a call.

### Bulkheads

You should have 4 small and 2 large wood discs. Take one large disc and one small disc. Glue them together as in step 1 below. Repeat for the remaining large disc and one small disc. You will now have two bulkheads, each consisting of a large disc and small disc. These are the **Electronics bay bulkheads**. We will get to the remaining two small discs later, put them aside for now.

Drill a 3-5mm hole in each of the Electronics bay bulkheads made in step 1, refer to step 2 for the position. Take an eye-bolt and install it into the hole you just made, refer to step 3. Note that the eye-bolt is secured with the 5mm lock-nut provided. Repeat this for the other bulkhead.

Take the 6mm by 220mm bolt. Thread the 6mm nut onto one side of the bolt, for about 30mm. Take a 6mm washer and put it over the short side of the bolt until it stops against the nut. Take one of the completed bulkheads and put the bolt with the short side first through the hole in the bulkhead, refer to step 3 for the proper orientation of the bulkhead and bolt. Take another 6mm washer and put it over the protruding bolt and secure with the lock-nut (dark gray nut in Step 3) supplied. This will be the Drogue section side bulkhead.

Once the Electronics bay is assembled the dome nut in step 4 will retain the loose bulkhead.

# Electronics bay bulkheads

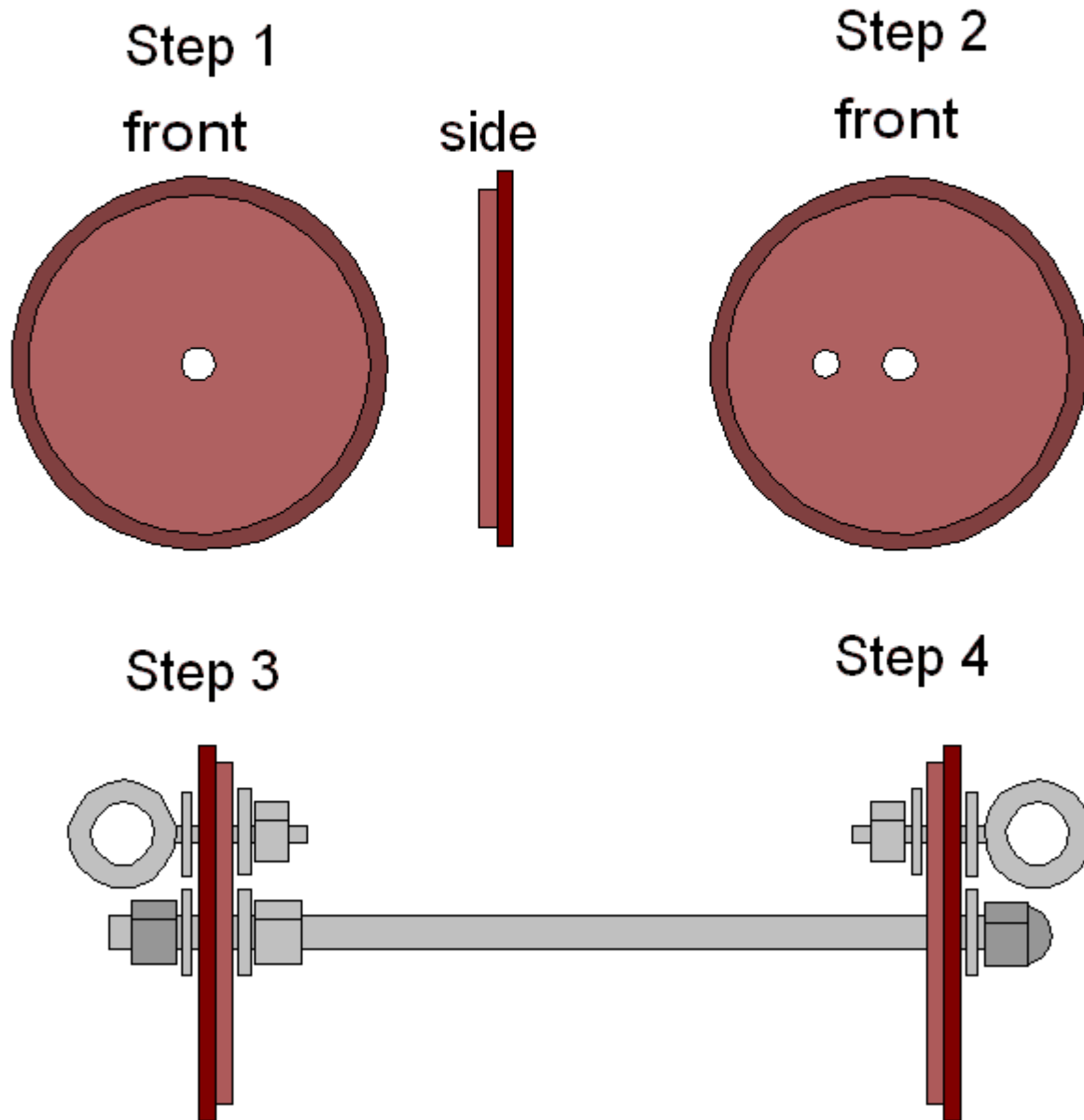

Now we get to the remaining two bulkheads. These bulkheads are used in the nosecone and the booster section. They are straightforward as they only get an eye-bolt through the existing hole in the centre. See below.

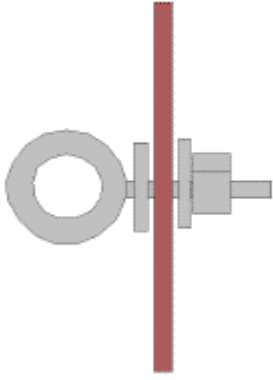

## Nosecone

The Nosecone should be sanded with a fine grit sandpaper to get a good finish. Apply some primer to see where the holes and other imperfections are. Fill these with automotive body filler (Spot putty). Let the filler dry fully and sand down again until you are happy with the look of the Nosecone.

## Fins

The fins can also be sanded at this point. I find it easier to sand the fins before installing them. Be sure to sand the root edge of the fins with some coarse sandpaper to allow the glue to stick to it very well. It is up to you if you would like to sand the fins to have a proper aerodynamic profile. If you wish, then the best is to give the leading edge a rounded shape and the trailing edge a sharp or tapered shape. If you want high performance and foresee that the rocket will go supersonic, make both the leading and trailing edges sharp.

## The Motor Mount Tube Assembly

The next step is to assemble the Motor Mount Tube (MMT). The function of this assembly is to centre the Motor in the Rocket and also provide a suitable mounting for the Fins. (Refer to the Overview drawing)

We will start with marking the tube. Take one end and make a mark at 10mm from the end. This will now be the **aft (rear)** end of the MMT. This is also where the aft Centring Ring (CR) will be glued on, at the **end** of the Rocket assembly. Take one of the fins and put it on the tube with the aft side of the fin touching the mark you just made. Make another mark just in front of the fin at about 259mm from the aft end of the MMT. This will be the location of the centre CR. The position of the forward CR is very important. If you place it too far forward the MMT won't fit properly into the Booster body tube. Make a mark on the MMT at 410mm from the aft end of the tube.

Now we will need to draw a line around the MMT at the marks we made. An easy way is to take a piece of thick paper or thin cardboard, wrap it around the MMT and making sure the ends align exactly, secure it with a piece of tape. You should line up the edge of the paper with the first mark. Draw a line around the tube by using the wrapped paper as a guide. Do the same for the other two marks.

Now that we have the location for the CRs marked, we can start to glue the centre and forward CRs. Don't glue the aft CR yet.

Mix up some epoxy and paint a little around the tube at the centre mark on the MMT. Slide a CR onto the MMT from the aft end. This will help to ensure that no glue is below the centre CR. Any glue below this mark will make installing the fins a difficult job later. The CR should stay on the tube without help, but some tape might be needed to keep it from sliding down if it is loose. Make sure the CR is on the MMT perfectly straight, as the fins will need to meet up with it later. Repeat for the forward CR. Note the Centre CR is supposed to be installed towards the front of the mark you made for it. The forward CR is supposed to be towards the aft of the mark you made for it.

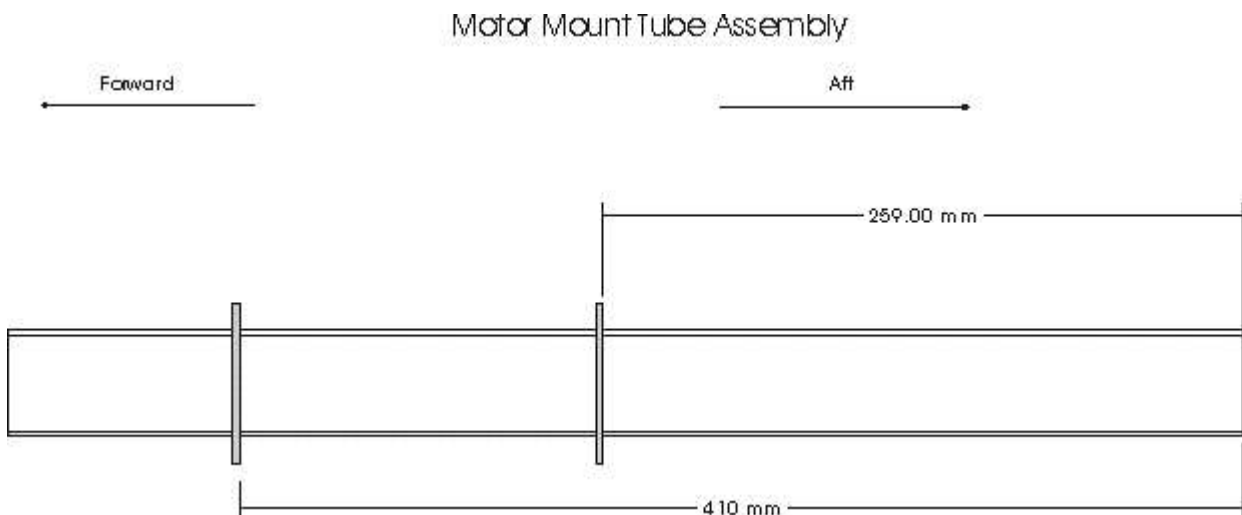

Make fillets only on the inside edges of the CRs. Note that the centre CR (left) has a fillet only on the side facing the forward CR (right), whereas the forward CR has a fillet on both sides. It is a good idea to first paint a little un-thickened epoxy onto the tube before adding the fillets. This will prevent the epoxy in the fillets to be absorbed by the cardboard tube.

## ***The Booster Assembly***

Now it's time to start the Booster assembly.

### **Fin slots**

First of all, the fin slots must be marked. Take the **Easy Fin Alignment guide**, put the Booster tube on the correctly sized circle on the guide. Now make a mark on the tube where the 3s are printed. This will be 120 degrees apart. (3 fins, 360 degrees in a circle,  $360 / 3 = 120$ ) Make another mark to the left of these marks. The space between the marks must be slightly wider than the fins. I usually aim for 4mm when using 3mm fins. Now take the small angle or use the door method to extend the marks down the tube for at least the length of the fins.

Now make a mark 10mm from the end where you drew the lines. This will be the aft end of the tube. Take a fin and put the aft side against the mark you made. Now make another mark just in front of the fins. Using the paper wrap method, draw a line around the tube at the two marks.

You will now have the slots marked out. Using a Stanley knife or similar, carefully cut out the slots. Use a straight edge to guide the knife and work slowly. If the tube has been reinforced with epoxy or fibreglass, cutting will be much more difficult. I'd recommend using a power tool to cut the slots.

I usually slip the MMT into the booster before cutting the slots to support the tube while cutting. Be careful not to damage the MMT while cutting the slots.

Once the slots have been cut, test fit the fins in the slots to see if they fit. Make the slots a little wider if the fins don't fit. Try to get a relatively tight fit as it makes installing the fins easier, since they won't fall out while working with the Booster.

### **Motor Mount Tube**

Installing the MMT into the Booster is quite simple. Mix up some epoxy and slip the MMT into the Booster until the aft end of the MMT is flush with the aft end of the Booster. Check that it fits properly. Now slide the MMT back until the centre CR is about 10mm below the forward side of the fin slots. Now drip some epoxy into the fin slots above the centre CR. Don't get any glue below the centre CR. Now slide the MMT forward until the aft end is flush with the aft end of the Booster. Turn the tube to allow the glue to flow around the inside of the Booster and around the MMT. This will secure the centre CR. Now put some glue onto the forward CR from the forward end of the Booster. Be very careful not to get any glue inside the MMT, as it will prevent a motor from sliding into the MMT properly. Put this aside to dry.

### **The Booster coupler**

The coupler on the Booster can now be made. Take the 140mm long piece of 65mm tube and glue a Bulkhead with an eyebolt installed into one end of the tube. Be sure to glue it a few millimetres into the tube. This will allow for a proper fillet to be made on the forward end of the tube. This fillet needs to be very strong as the weight of the booster and motor will pull against it. It is advised to reinforce the entire bulkhead to prevent the eye-bolt from breaking loose. This can be done by simply filling the cavity with epoxy thickened with cotton flocks.

The coupler tubing is sometimes a loose fit inside the Body tubes. To ensure that it is properly centred, add a few layers of tape around the aft side and at about the centre of the coupler. I usually make sure that the tape around the middle is just inside the Booster when the coupler is installed. If the coupler is a very tight fit, you may have to remove the outer layer of paper from the coupler. Be careful not to remove too many layers.



Now put some glue around the inside of the forward end of the Booster tube. Slip the coupler with open end first, into the Booster's forward end until it stops against the forward CR. This will ensure that the entire Booster is one solid thrust-bearing unit. Wipe any excess epoxy away. Allow to dry.

### Motor retention

The Rocket Motor needs to be retained inside the booster so it won't fall out during recovery.

All the motors from ASR now comes with a bulkhead threaded to take a 6mm threaded rod. This eliminates the need for the two bolts at the back of the booster. The threaded rod is screwed into the bulkhead of the rocket motor and protrude from the booster coupler bulkhead. A washer and nut is then used to retain the threaded rod and the motor.

## Booster Section Assembly

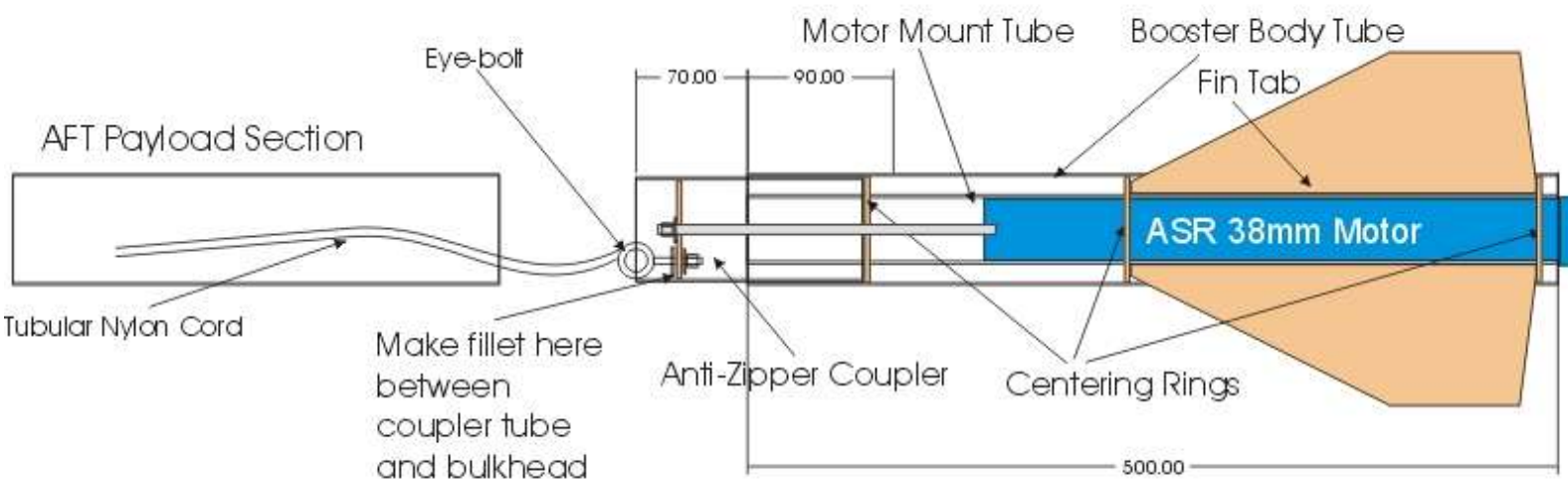

## ***Installing the fins***

Make sure the fins have been sanded lightly on the root edges. Make sure the root edges are still square, otherwise they will not fit properly onto the MMT.

Apply some epoxy to the root edge of one fin and install it through the fin slot. I use epoxy thickened with Cotton Flocks. Make sure it stops squarely against the MMT. Verify that it is perpendicular to the MMT. Use tape to hold the fin straight until the epoxy has set. To help keep the MMT straight while installing the fins, put the aft CR onto the MMT. Don't push the aft CR onto the MMT all the way otherwise you may not be able to get it out again. Also, be careful not to glue it in yet. Do the remaining fins, one at a time. Don't be tempted to do them all at once unless you have a proper jig to hold the fins straight.

Once all the fins are installed, we now have to make fillets on the inside and outside of the Booster tube where the fins meet up with it. Also where the fins meet the MMT. The inside fillets are for strength and the outside fillets for strength and aerodynamic purposes. Use thickened epoxy for making fillets. For more information about making fillets, visit [www.jcrocket.com](http://www.jcrocket.com) or phone us.

After making the inside fillets, you can now glue the aft CR in place. Remember to check the requirements for **motor retention**. Some methods require that the retention be installed before installing the aft CR.

Once the aft CR is glued in, be sure to leave the space between the MMT and the booster body tube open. This will allow you to use the ASR Rocket Tailpiece or similar motor retention.

## The Electronics Bay

This assembly is very straightforward. Take one assembled bulkhead with an eyebolt installed, put the 6mm bolt through the centre hole and secure with a nut, washer and lock-nut. Take the 200mm long piece of 65mm tubing, slip the bulkhead and bolt assembly, bolt first into the tube. Now take another bulkhead assembly and slip it over the centre bolt. Take the remaining washer and wing-nut and thread it onto the bolt.

To secure the Drogue and Main payload sections to the electronics bay, we recommend using self-tapping screws of 5mm diameter and no longer than 15mm. Use at least two screws on each side of the Electronics bay. Be sure not to damage the electronics with the placement of the retaining screws.

Remember if you are going to use an Altimeter, you will need to drill holes into the Electronics Bay for the outside pressure to be sensed inside the bay. For most Altimeters 3 holes, 2mm in diameter and spaced equally around the bay is fine. Make sure to drill the holes on the forward part of the bay. The joint in the middle of the bay, caused by the two body tubes, may cause turbulence that may affect the Altimeter.

Also consider glueing the drogue side bulkhead permanently into the electronics bay tube. This will prevent ejection charge gasses from entering into the bay.

Always follow the instructions that came with your Flight electronics.

## Electronics Bay Assembly

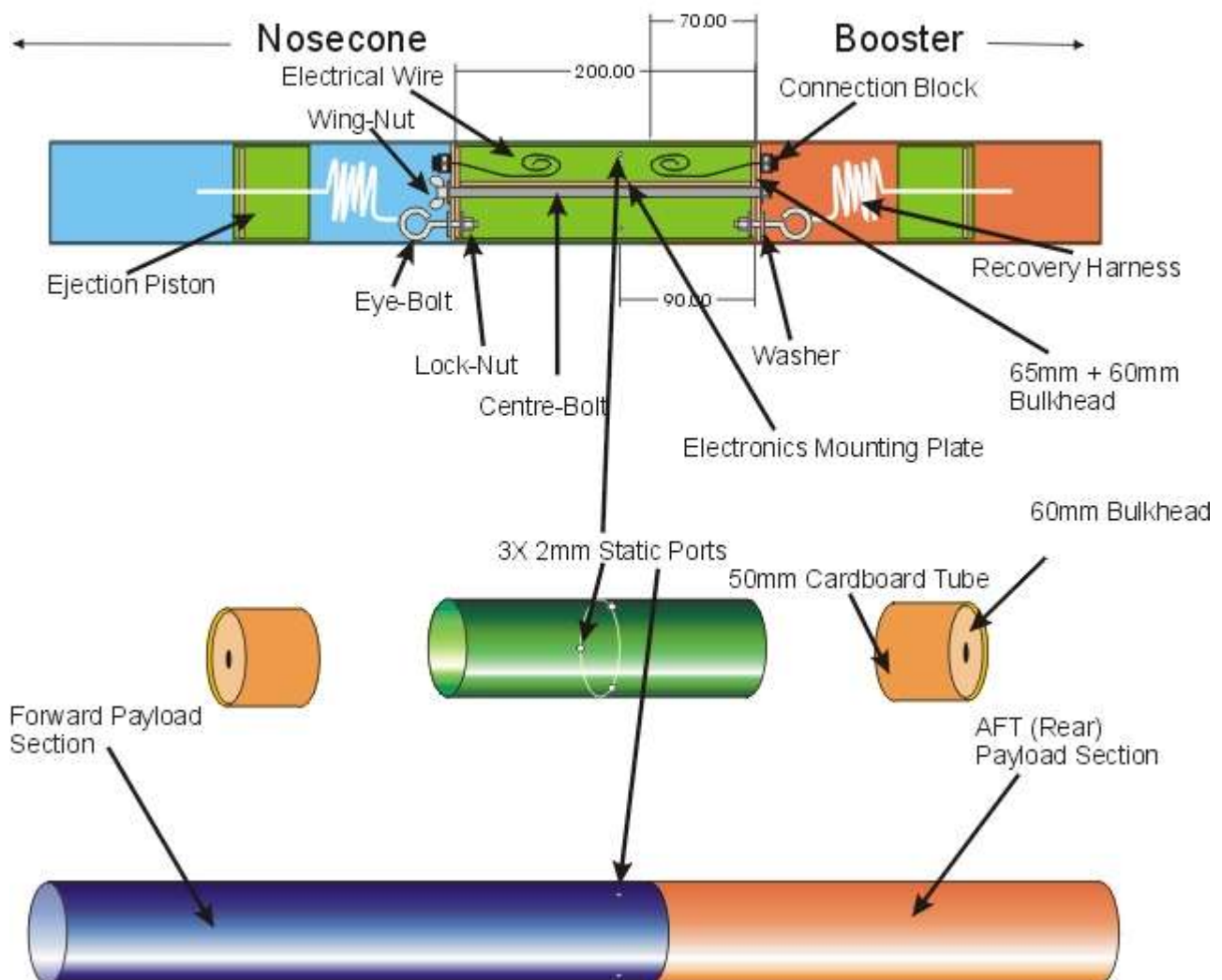

# Final assembly

All that remains is to install the Electronics Bay into the Rocket body. The Electronics bay is also the coupler for the aft and forward payload sections. Make sure that it fits very tightly in the body tube. If needed, use masking tape to make the circumference of the coupler tube bigger, until it fits properly.

Position the Electronics Bay about 80mm into the aft (drogue) payload section. Measure 70mm from the forward end of the aft payload section and make mark around the tube. Drill a hole through the tubes at two or three locations on this mark around the tube. These holes will be for the retaining screws that hold the tubes together. Use any self-tapping screw in the range of 4 – 6mm to hold the tubes together. The forward payload section is secured in the same way. The only difference is the holes must be at 110mm from the aft side of the forward payload section.

The shock cord (harness) can be tied directly to the eyebolts. I prefer to use quick links to attach the shock cord to the eyebolts. This makes it easy to add/remove a shock cord when sharing a recovery system with other Rockets.

## ***Finishing***

The finish of your Rocket depends greatly on how much effort you want to put into it. Some people leave their Rocket completely unpainted and others go overboard with details. It's up to you!

Wood filler is used to fill the spirals on the tube, if needed. It doesn't affect the performance much but it makes the Rocket look great!

Sanding sealer can be used to cover the Rocket to give it nicer finish than plain cardboard. It also allows the tubes to be painted with great results.

Epoxy coating gives a nice finish and adds some strength to the Rocket. I'd recommend applying two layers of epoxy.



Fibre glassing the tubes is the best. It makes the tubes very strong and durable. As a bonus the spirals in the tubes don't need to be filled beforehand and the tubes can also be finished to a glass-like shine. A single wrap of 100g cloth is fine for a rocket like the StarChaser 2.

Most people use spray cans to paint their Rockets. They are quick and inexpensive for small projects. Large projects however, can cost a bundle if you don't have access to a proper paint system.

To get the best results use a good primer before applying the colour paint. This will ensure that the colours are even. After applying the primer, check the rocket body for any imperfections. It is up to you how well you want the Rocket to look. I usually check for major dents and fill them with spot putty. Remember that the small imperfections will not be easily visible. Also, gloss paint will never hide the imperfections. It will only make it stand out more.

After the Rocket has been painted, it is time to install the Launch lugs. I do this after finishing the Rocket so I don't have to mask off the lugs before painting.

Cut a small slot near the aft end of the booster and another one just below where the coupler extends out of the booster. These slots should be in a straight line. Put epoxy into the hole and into the loop of the lug. Press it into the slot and secure with tape until the glue has set.



Your Rocket is now complete!

## ***Preparing the Rocket for flight***

This is done at the Launch site. The proper fitting of components will be checked as well as the stability of each Rocket to ensure safety.

The flight electronics can be a simple **Timer** to release the parachutes after a fixed time has elapsed or an **Altimeter** with altitude and dual-deployment abilities.

The launch area and ground support also determines the success of the Rocket.

## ***Appendix A – Fin Terminology***

# Fin Terminology

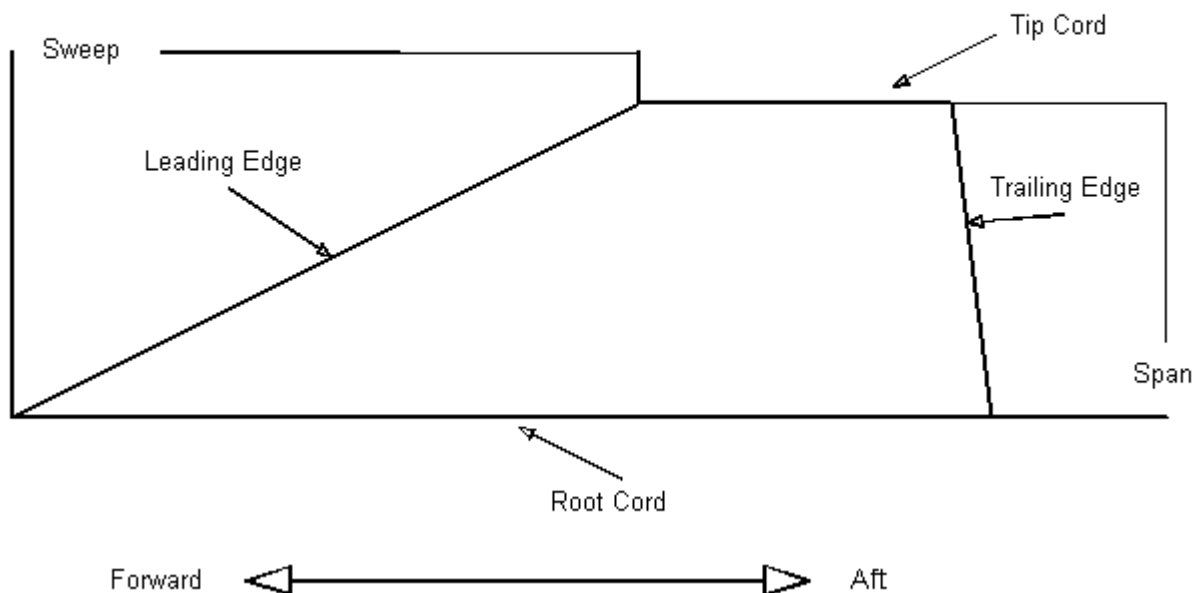

Attach the main chute to the forward shock cord about 1m from the nosecone. This will ensure that the nosecone doesn't hit the payload section during descent.

Attach the drogue chute about 1m from the aft payload to ensure that the booster is further away from the chute as the payload.

